

# REVOLVING TRANSPORT TROLLEYS JKB

**For loads up to 12 metric tons, height 110 mm**

## **i** DESCRIPTION

- Optional connecting bars can be fixed without tools by clamping down on adapter.
- High load capacity at low weight.
- Bearing supported swiveling castors allow 360° maneuverability.
- Mix and match revolving trolleys with transport trolleys: JKB 2 to JKB 8 have same height as transport trolleys series K.
- All products are also available in a set of two with price advantage.
- In addition, all the trolleys have a platform center hole to allow attachment to the load.
- Using the slots in the platform, the trolleys JKB 3 - 8 can be affixed to the load with standard lashing belts.
- Pulling handle and connecting bars available as accessories (see pages 66-67).
- Unrivalled: The narrow castors reduce rolling and turning resistance to a minimum.
- For choosing the adequate revolving trolley we recommend a load of two-third of the maximum capacity. This will be the most advantageous compromise between payload, ergonomics and handling of the devices.
- The load capacity specifications refer to a maximum speed of 2 km/h.



Loads up to		2 t		4 t	
TYPE		■ JKB 2 K		■ JKB 1,5 SET	
Consist of		1 x JKB 2 K		2 x JKB 2 K	
Load capacity	kg	2 000		2 x 2 000	
Number of castors	Pieces	6		2 x 6	
Castor dimensions	Ø x l mm	85 x 43		85 x 43	
Height	mm	110		110	
Supporting surface per cassette	Ø C mm	150		150	
Cassette dimensions	L1 x B1 mm	528 x 495		528 x 495	
Weight JUWAmid	kg	20		40	
<b>ORDER NO. with JUWAmid</b>		■ 14 020 085-P		■ 14 020 085-D	
<b>ORDER NO. with JUWathan®</b>		■ 14 020 085-VU		■ 14 020 085-DVU	

**TESTED**

 according to technical  
 regulation ANSI/ASME  
 (USA)

Revolving trolley JKB in action.

▶ **EXAMPLE FOR LOAD DISTRIBUTION**  
**9 metric tons trolley combination:**

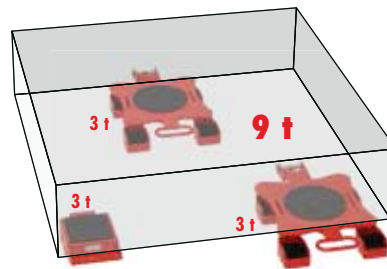

Loads up to		4 t	8 t	6 t	12 t
TYPE		JKB 4 K	JKB 4 SET	JKB 6 K	JKB 6 SET
Consist of		1 x JKB 4 K	2 x JKB 4 K	1 x JKB 6 K	2 x JKB 6 K
Load capacity	kg	4 000	2 x 4 000	6 000	2 x 6 000
Number of castors	Pieces	12	2 x 12	16	2 x 16
Castor dimensions	Ø x l mm	85 x 43	85 x 43	85 x 43	85 x 43
Height	mm	110	110	110	110
Supporting surface per cassette	Ø C mm	250	250	250	250
Cassette dimensions	L1 x B1 mm	690 x 475	690 x 475	675 x 525	675 x 525
Weight JUWAmid	kg	38	76	41	82
<b>ORDER NO. with JUWAmid</b>		■ 14 041 085-P	■ 14 041 085-D	■ 14 061 085-P	■ 14 061 085-D
<b>ORDER NO. with JUWathan®</b>		■ 14 041 085-VU	■ 14 041 085-DVU	■ 14 061 085-VU	■ 14 061 085-DVU

# REVOLVING TRANSPORT TROLLEYS JKB

For loads up to 28 t metric tons, height 110 mm/180 mm

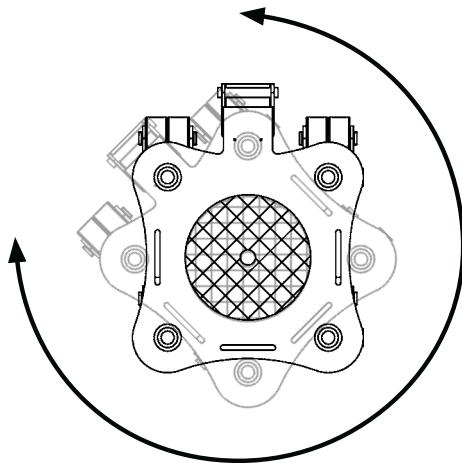

360° rotation in all directions



Revolving trolley JKB in action

For information on matching  
**ACCESSORIES**  
see **Pages 66-67.**



Loads up to		8 t	16 t
TYPE		JKB 8 K	JKB 8 SET
Consist of		1 x JKB 8 K	2 x JKB 8 K
Load capacity	kg	8 000	2 x 8 000
Number of castors	Pieces	20	2 x 20
Castor dimensions	Ø x l mm	85 x 43	85 x 43
Height	mm	110	110
Supporting surface per cassette	Ø C mm	250	250
Cassette dimensions	L1 x B1 mm	895 x 740	895 x 740
Weight JUWAmid	kg	64	128
<b>ORDER NO. with JUWAmid</b>		■ 14 080 085-P	■ 14 080 085-D
<b>ORDER NO. with JUWathan®</b>		■ 14 080 085-VU	■ 14 080 085-DVU

**TESTED**

 according to technical  
 regulation ANSI/ASME  
 (USA)

## **i** DESCRIPTION

- JKB 10 G/JKB 14 G have same height as transport trolleys series G.
- Connecting bars as standard 2000 mm, can be offered up to 3 m length.
- High load capacity at low weight.
- Bearing supported swiveling castors allow 360° maneuverability.
- All products are also available in a set of two with price advantage.
- In addition, all the trolleys have a platform center hole to allow attachment to the load.
- Unrivalled: The narrow castors reduce rolling and turning resistance to a minimum.
- Pulling handle and connecting bars available as accessories (see pages 66-67).
- For choosing the adequate revolving trolley we recommend a load of two-third of the maximum capacity. This will be the most advantageous compromise between payload, ergonomics and handling of the devices.
- The load capacity specifications refer to a maximum speed of 2 km/h.



Loads up to		10 t	20 t	14 t	28 t
TYPE		■ JKB 10 G	■ JKB 10 SET	■ JKB 14 G	■ JKB 14 SET
Consist of		1 x JKB 10 G	2 x JKB 10 G	1 x JKB 14 G	2 x JKB 14 G
Load capacity	kg	10 000	2 x 10 000	14 000	2 x 14 000
Number of castors	Pieces	8	2 x 8	12	2 x 12
Castor dimensions	Ø x l mm	140 x 59	140 x 59	140 x 59	140 x 59
Height	mm	180	180	180	180
Supporting surface per cassette	Ø C mm	250	250	250	250
Cassette dimensions	L1 x B1 mm	975 x 665	975 x 665	975 x 720	975 x 720
Weight JUWathan®	kg	127	254	148	296

**ORDER NO. with JUWathan®**

■ 14 101 140-VU

■ 14 101 140-DVU

■ 14 140 140-VU

■ 14 140 140-DVU